

BUILDING AUTOMATION
CONTROL TECHNOLOGY
SENSOR TECHNOLOGY

alre



STELLA
with automatic
hydraulic balancing.

NEW TO THE FAMILY, **STELLA**



AUTOMATIC HYDRAULIC BALANCING

The new cyclically operated actuator completely redefines heating/cooling circuit regulation. With an infinitely variable open position (with room controller) and the use of the Stella AI, perfect hydraulic balancing of surface heating circuits becomes child's play. Convenient, simple and reliable. Stella can be used as a 'plug-and-play' solution on all common distribution systems.

- + Sensor: external 2K NTC (HF-8/4-K2 is part of the scope of delivery)
- + Replaces all conventional actuators and fits valves from all well-known manufacturers.
- + Hydraulic balancing of the latest generation: The Stella AI recognises user behaviour and system environment independently and regulates permanently and according to demand.
- + The additional costs compared to conventional actuators are amortised directly with the installation due to the time saved, as a calculation and the manual execution of the hydraulic balancing are completely unnecessary.
- + 'Plug-and-Play': No special commissioning or parameterisation necessary.
- + Can be used without additional components such as routers, gateways or app control.

DATA & FUNCTIONS

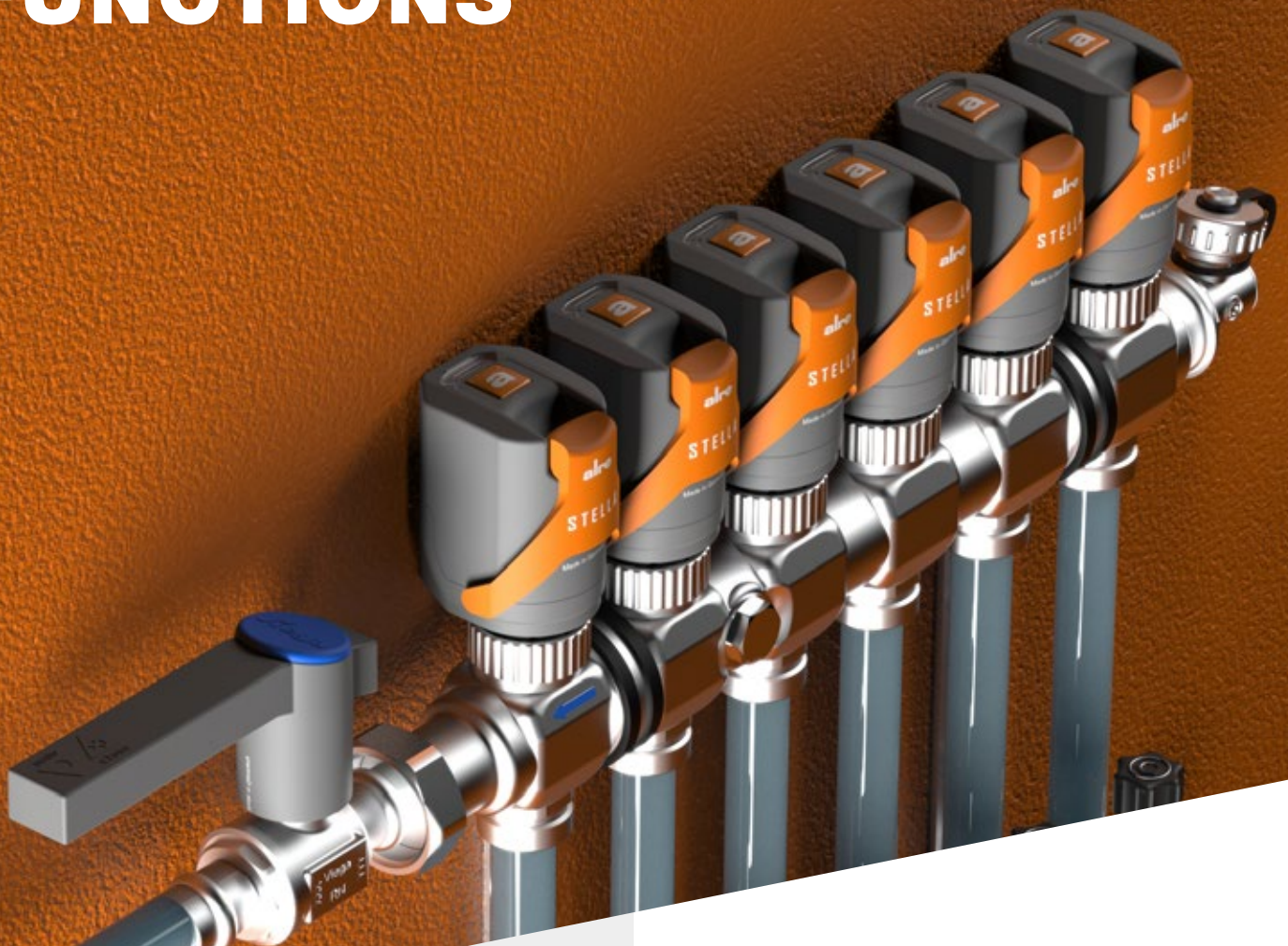

STELLA

is an intelligent autonomous electrothermal actuator 230 V NC and takes over the adaptive and demand-oriented hydraulic balancing of the surface heating or cooling circuits of a manifold for heating/cooling by means of artificial intelligence.



AUTOMATIC HYDRAULIC BALANCING



ARTIFICIAL INTELLIGENCE



TIME SAVING

- + Combinable with every common temperature controller and terminal strip (except devices with switching element Triac).
- + for heating and cooling systems
- + folding lever for easy unscrewing or for manual opening of the thermostatic valve disconnected from the mains
- + Temperature sensors suited for surface heating pipes made of plastic, metal or combinations thereof with an external diameter of 12 to 20 mm, M 30x1.5
- + measures a heating circuit's outflow temperature
- + The range of setpoint temperatures Stella calculates is variable and dependent on user behaviour and the system's environment
- + any valve position between OPEN and CLOSED can be approached and held
- + An expansion element and a path measurement system are needed to position the valve lift

THE PERFECT TEAM AS A SET



5x

FTR (Set 32)
Flush-mounted
bimetal

or



5x

Berlin 1000 (Set 31)
controller

1x
Terminal strip
with 6 channels



6x

Actuator for
automatic
hydraulic
balancing



THE CLASSIC **BERLIN 1000.** **PROVEN QUALITY.**



INCREDIBLY SLIM.

Our surface-mounted thermostats featuring Berlin 1000 design have been unrivalled as the slimmest electromechanical surface-mounted controller on the market since 2007. The minimalist design, long life and quality distinguishes this range and has become a customer favourite. It regulates or monitors temperatures in offices, living spaces, hotels, hospitals, etc. and is available in different variants depending on the requirements of the project.

- + up to 10 actuators for valves can be connected
- + highest energy efficiency due to low power consumption in control operation and no power consumption outside control operation
- + high degree of sustainability due to low component and resource use, recyclable plastics and long service life
- + super slim timeless design that fits into any environment
- + Dimensions of housing:
78x13.9x78.5 mm
- + mechanical, AP, 5 to 30 °C, NC, 230VAC
- + pure white RAL 9010, other colour variants such as RAL 9016 also available

THE NEAT FREAK, FOR CLEAN CABLE MAN- AGEMENT THAT ENSURES A PERFECT OVERVIEW

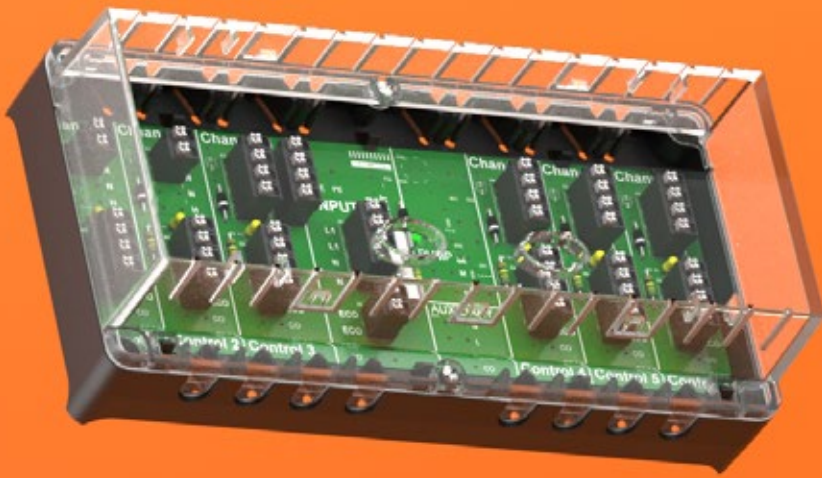

IT DOES NOT GET ANY CLEARER THAN THIS

With our terminal strips, temperature controllers and electrothermal actuators in connection with hot water underfloor heating systems can be wired quickly, clearly and conveniently in the heating manifold.

- + quick, clear wiring of the temperature controllers and actuators through screwless spring terminals
- + comfortable and simple installation in the heating manifold via surface-mounted/ wall-mounted, hat rail mounting (EN 60715) or magnetic bases
- + high time and cost savings
- + Labelling fields for safe allocation of the heating circuits
- + integrated strain relief for connecting cables

GET UP TO 20% SUBSIDY FOR OPTIMISING YOUR HEATING SYSTEM!



A BLESSING FOR THE ENVIRONMENT AND THE WALLET

The German Federal Office for Economic Affairs and Export Control (BAFA) has launched a subsidy programme for heating optimisation. The aim of the subsidy programme is to motivate homeowners to renew their heating systems with attractive, non-repayable subsidies. Among other things, this is intended to make an important contribution to the environmentally friendly supply of heat in Germany.

- + Replaces all conventional actuators and fits valves from all well-known manufacturers.
- + The system as a measure for heating optimisation in existing buildings that are at least 5 years old (e.g. hydraulic balancing including replacement of heating pumps).
- + Application for heating optimisation is also possible without energy efficiency expert
- + In order to prove the optimisation measure, the specialist technician must fill out the VdZ [Association of the German Central Heating Industry] form and provide the services to be proven.
- + Under 'Remarks', it makes sense to indicate that the hydraulic balancing is carried out with Stella.
- + The system is also possible as a partial measure for the energy refurbishment of existing buildings according to BEG WG or NWG further information at: www.bafa.de



**SECURE
YOUR SUBSIDY.**



ACTUATOR 'STELLA' 230 V NC

FOR AUTOMATIC HYDRAULIC COMPARISON



TECHNICAL DATA

Operating voltage:	230 V~, 50 Hz
Max. power consumption:	30 W
max. starting current:	approx. 0.13 A
Housing colour:	grey-orange
Housing material:	PA6 plastic
Ambient temperature:	0 ... 50 °C
Storage temperature:	-25 to +60 °C
Permissible atmospheric humidity:	Max. 95 % rel. humidity, non-condensing
Mounting/attachment:	M 30x1.5
Protection rating:	IP54
Protection class:	II
Safety and EMC:	according to DIN EN 60730
Average power consumption:	approx. 1.7 W
Opening/closing time:	approx. 3 min
Nominal stroke:	3.5 mm
Function type:	normally closed
Nominal closing force:	110 N
Connecting cable:	1 m / 2x0.34 mm ²



APPLICATION

'Stella' – the intelligent autonomous 230 VAC NC electrothermal actuator for automatic adaptive hydraulic comparison of heating manifolds' heating circuits in surface heating and surface cooling systems.

Sensors on the supply and return lines measure temperature differences and algorithm continuously calculates the necessary temperature spread and the appropriate valve position.

Normally closed and features a folding lever for easily unscrewing the thermostat valve or opening it manually when it is disconnected from the mains. With integrated inflow temperature limitation.

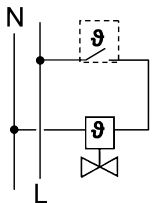
Combinable with every common temperature controller and terminal strip (except devices with switching element Triac).

TYPE/IMAGE	ITEM NO.	FEATURES	CIRCUIT DIAGRAM	EURO/PG
ZB00A-010.185 	G8990010	Actuator for automatic hydraulic comparison		
SET 31 	VV000046	Set for performing fully automatic hydraulic comparison consisting of 5 surface-mounted room thermostats, 1 terminal strip and 6 actuators.		
SET 32 	VV000047	Set for performing fully automatic hydraulic comparison consisting of 5 flush-mounted room thermostats, 1 terminal strip and 6 actuators.		

ILLUSTRATIONS



BRIEF DESCRIPTION

- Combinable with the commercial two-point room temperature controller (electromechanical, electronic, PWM), except devices with switching element Triac
- For heating and cooling systems
- Features a folding lever for easily unscrewing the thermostat valve or opening it manually when it is disconnected from the mains
- Temperature sensors suited for surface heating pipes made of plastic, metal or combinations thereof with an external diameter of 12 to 20 mm
- Measures a heating circuit's outflow temperature
- The range of setpoint temperatures Stella calculates is variable and dependent on user behaviour and the system's environment
- The valve can be adjusted to any desired position between OPEN and CLOSED and set to remain in that position.
- An expansion element and a path measurement system are needed to position the valve lift.



ROOM TEMPERATURE CONTROLLER, MECHANICAL, RTBSB

SURFACE-MOUNTED 'SUPER-THIN' INSTALLATION – DESIGN BERLIN 1000



TECHNICAL DATA

Design:	Berlin 1000
Surface finish:	glossy
Housing colour:	pure white, like RAL 9010
Housing material:	ABS plastic
Ambient temperature:	0 ... 30 °C
Storage temperature:	-20 ... +70 °C
Permissible atmospheric humidity:	Max. 95 % rel. humidity, non-condensing
Electrical connection:	screw-type terminals 0.33 mm ² to 1.5 mm ²
Mounting/attachment:	Surface / wall mounting (4-hole assembly on flush-mounted socket)
Protection rating:	IP30
Safety and EMC:	according to DIN EN 60730
Average power consumption:	< 0.25 W
Max. switching current:	2 (1) A
Switching element:	bimetallic contact
Sensor:	bimetal
Control range:	5 ... 30 °C
Hysteresis:	approx. 0.5 K at a temperature change of max. 4 K/h
General features:	mechanical range limitation; thermal feedback; external setting

APPLICATION





Control or monitoring of temperatures in closed spaces.

Valve actuator: normally closed. If normally open heating valves are available, they should be connected with the cooling output of the changeover switch (toggler).

Up to a maximum of 10 actuators for valves can be connected (normally closed, NC); with a toggler, on the NO contact, up to 5 units (in this context, please check the switching capacity listed in the technical specifications).

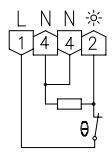



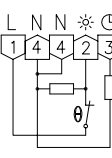

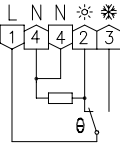

Installation note: Owing to the existing wiring space in the controller itself, installation on a flush-mounted socket is recommended, but it can also be performed on a plane, non-conducting substrate.

Explanations of technical terms can be found in the annex to the product catalogue or at www.alro.de.

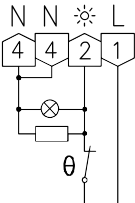
TYPE/IMAGE	ITEM NO.	FEATURES	CIRCUIT DIAGRAM	EURO/PG
	MA300000	General features: scale: degrees Celsius Operating voltage: 230 VAC, 50 Hz Protection class: II, if properly mounted Max. switching voltage: 230 VAC, 50 Hz Min. switching voltage: 230 VAC, 50 Hz Switching power: 460 W Switching contact: NC contact (max. 10 actuators) Output signal: switching (230 VAC, 50 Hz) Control function: heating		
	MA300008	Like RTBSB-201.000 but with multi-digit display 1 to 6		
	MA300800	Like RTBSB-201.000 but with housing colour: Traffic / studio white, similar to RAL 9016		
	MA300100	General features: ECO function; scale: degrees Celsius Operating voltage: 230 VAC, 50 Hz Protection class: II, if properly mounted Max. switching voltage: 230 VAC, 50 Hz Min. switching voltage: 230 VAC, 50 Hz Switching power: 460 W Switching contact: NC contact (max. 10 actuators) Output signal: switching (230 VAC, 50 Hz) Control function: heating Input 'temperature reduction': approx. 3 K (230 VAC, 50 Hz)		

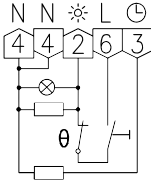
ROOM TEMPERATURE CONTROLLER, MECHANICAL, RTBSB

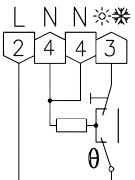
SURFACE-MOUNTED 'SUPER-THIN' INSTALLATION – DESIGN BERLIN 1000

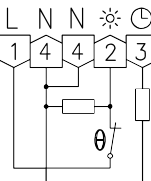
TYPE/IMAGE	ITEM NO.	FEATURES	CIRCUIT DIAGRAM	EURO/PG
	MA300200	General features: scale: Degrees Celsius Operating voltage: 230 VAC, 50 Hz Protection class: II, if properly mounted Max. switching voltage: 230 VAC, 50 Hz Min. switching voltage: 230 VAC, 50 Hz Switching power: 460 W Switching contact: changeover switch (toggler, max. 10 actuators (NC contact), max. 5 actuators (NO contact)) Output signal: switching (230 VAC, 50 Hz) Control function: Heating or cooling		
	MA301400	General features: 'heating' display; scale: degrees Celsius Operating voltage: 230 VAC, 50 Hz Protection class: II, if properly mounted Max. switching voltage: 230 VAC, 50 Hz Min. switching voltage: 230 VAC, 50 Hz Switching power: 460 W Switching contact: NC contact (max. 10 actuators) Output signal: switching (230 VAC, 50 Hz) Control function: heating		
	MA300400	General features: ECO function; 'heating' display; scale: degrees Celsius; 'on/off' switch Operating voltage: 230 VAC, 50 Hz Protection class: II, if properly mounted Max. switching voltage: 230 VAC, 50 Hz Min. switching voltage: 230 VAC, 50 Hz Switching power: 460 W Switching contact: NC contact (max. 10 actuators) Output signal: switching (230 VAC, 50 Hz) Control function: heating Input 'temperature reduction': approx. 3 K (230 VAC, 50 Hz)		
	MA300500	General features: Climate controller for 2-pipe systems, especially heat pumps; scale: Degrees Celsius; 'heating / cooling' switch Operating voltage: 230 VAC, 50 Hz Protection class: II, if properly mounted Max. switching voltage: 230 VAC, 50 Hz Min. switching voltage: 230 VAC, 50 Hz Switching power: 460 W Switching contact: Changeover switch (toggler, max. 5 actuators) Output signal: switching (230 VAC, 50 Hz) Control function: Heating or cooling		
	MA300502	Like RTBSB-201.065 but with multi-digit display 1 to 6		
	MA302100	General features: ECO function; scale: degrees Celsius Operating voltage: 24 VAC, 50 Hz Protection class: III Max. switching voltage: 24 VAC, 50 Hz Min. switching voltage: 24 VAC, 50 Hz Switching power: 48 W Switching contact: NC contact (max. 5 actuators) Output signal: switching (24 VAC, 50 Hz) Control function: heating Input 'temperature reduction': approx. 3 K (24 VAC, 50 Hz)		



ROOM TEMPERATURE CONTROLLER, MECHANICAL, RTBSB

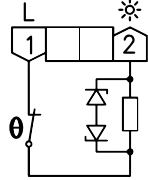

SURFACE-MOUNTED 'SUPER-THIN' INSTALLATION – DESIGN BERLIN 1000

TYPE/IMAGE	ITEM NO.	FEATURES	CIRCUIT DIAGRAM	EURO/PG
	MA304000	<p>General features: 2-wire room temperature controller; multi-digit display * to 6</p> <p>Operating voltage: 230 VAC, 50 Hz</p> <p>Ambient temperature: 0 to 30 °C</p> <p>Protection class: II, if properly mounted</p> <p>Max. switching current: 20 mA</p> <p>Min. switching current: 5 mA</p> <p>Max. switching voltage: 230 VAC, 50 Hz</p> <p>Min. switching voltage: 230 VAC, 50 Hz</p> <p>Switching power: 4.6 W (max. 2 actuators)</p> <p>Switching contact: NC contact</p> <p>Output signal: switching (230 VAC, 50 Hz)</p> <p>Control function: heating</p> <p>Control range: 5 to 30 °C</p> <p>Hysteresis: approx. 0.5 K at a temperature change of max. 4 K/h (load-dependent)</p>		

Accessories: terminal strips V00xx, suitable valve actuators ZB00A



You can find other / similar controllers with outputs for heating / cooling and noiseless controllers in the 'Air Conditioning Technology' chapter (note: applies to KTRTB, for example)

ACCESSORIES	ITEM NO.	FEATURES	EURO/PG
	MN990006	Adapter frame for mounting room temperature controllers of the Berlin 1000 series in flush-mounted sockets up to 80x80 mm	
	MA990000	Adjusting knob for B1000 series devices, scale: Degrees Celsius, pure white glossy	
	MA990001	Adjusting knob for B1000 series devices, multi-digit display 1 to 6, pure white glossy	

ILLUSTRATIONS

RTBSB-201.xxx / KTRTB

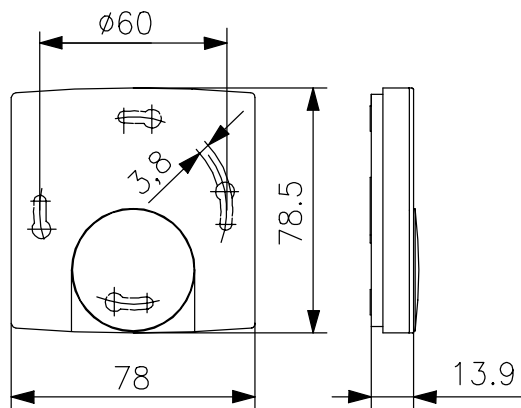

RTBSB-201.xxx with 'ON/OFF' switch at the side

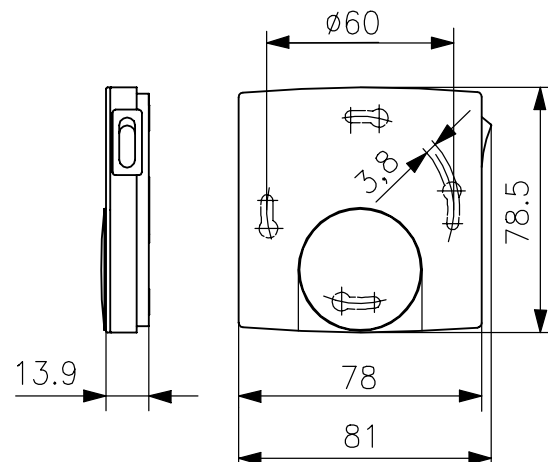



TERMINAL STRIP FOR HEATING MANIFOLD

FOR 6 OR 8 ROOM THERMOSTATS

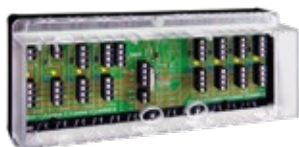



TECHNICAL DATA

Surface finish:	Upper part glossy, lower part matt
Housing colour:	Upper part transparent, lower part anthracite grey, similar to RAL 7016
Housing material:	PC plastic
Operating voltage:	230 VAC/50 Hz
Ambient temperature:	-10 ... +50 °C
Storage temperature:	-20 ... +70 °C
Permissible atmospheric humidity:	Max. 95% rel. humidity, non-condensing
Electrical connection:	spring terminals 0.75 mm ² to 1.5 mm ² for rigid cables 0.5 mm ² to 1 mm ² for flexible cables
Protection rating:	IP20
Mounting/attachment:	convenient and simple installation in the heating manifold via hat rails (standard rail or supporting rail EN 60715) or magnetic bases Surface/wall mounting with 4 fastening screws included in delivery or using optional JZ-32 magnetic fastening set
Protection class:	II, if properly mounted
Control function:	Heating or cooling
General features:	Ready for operation display (mains voltage), active channels display, integrated strain relief, labelling fields

APPLICATION

Terminal strip for heating controller with or without ECO function, also for heating/cooling controller with integrated heating/cooling switch. Depending on the controller used, actuators can be connected in the NC (normally closed) or NO (normally open) mode of operation.

Can be set up with master-slave control when using a clock regulator or an external timer.

TYPE/IMAGE	ITEM NO.	FEATURES	EURO/PG
VOOPL-216.176 	DA480510	General features: Terminal strip in housing for wiring up to 6 room thermostats and up to 12 actuators; (channel 1–2: 1 actuator/channel 3: 4 actuators/channel 4–6: 2 actuators), T3,15 A/250 V device fuse, installation dimensions Ø 5x20 mm (also secures the circuits of the connected controllers and valve gears)	
VOOPL-318.178 	DA480520	General features: Terminal strip in housing for wiring up to 8 room thermostats and up to 16 actuators; (channel 1–2: 1 actuator/channel 3, 5–8: 2 actuators/channel 4: 4 actuators), T3,15 A/250 V device fuse, installation dimensions Ø 5x20 mm (also secures the circuits of the connected controllers and valve gears)	

other/similar items: VOORL terminal strip for heating and cooling in the air conditioning technology section
Accessories: suitable valve actuators ZB00A

ACCESSORIES	ITEM NO.	FEATURES	EURO/PG
JZ-32 	BN990005	General features: Magnetic fastening set for simple and safe fastening of the VOOPL terminal strip on a metallic substrate (for example, heating manifold)	



TERMINAL STRIP FOR HEATING MANIFOLD

FOR 6 OR 8 ROOM THERMOSTATS

ILLUSTRATIONS

V00PL-216.176

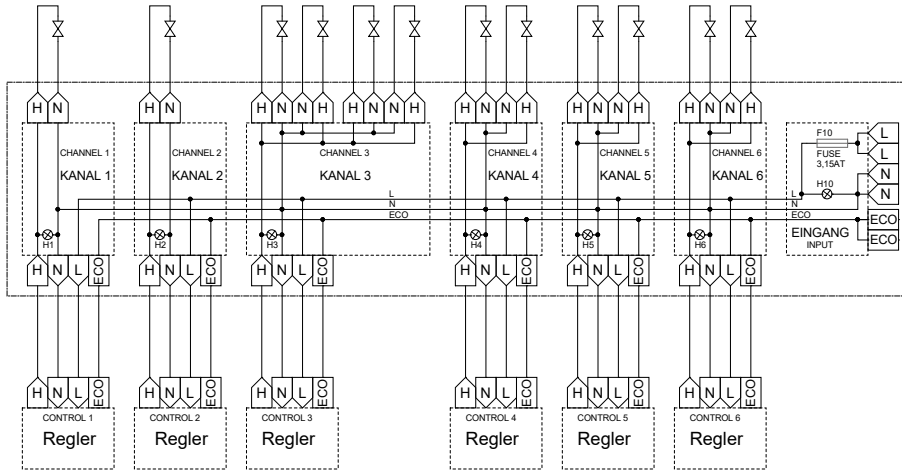

V00PL-318.178

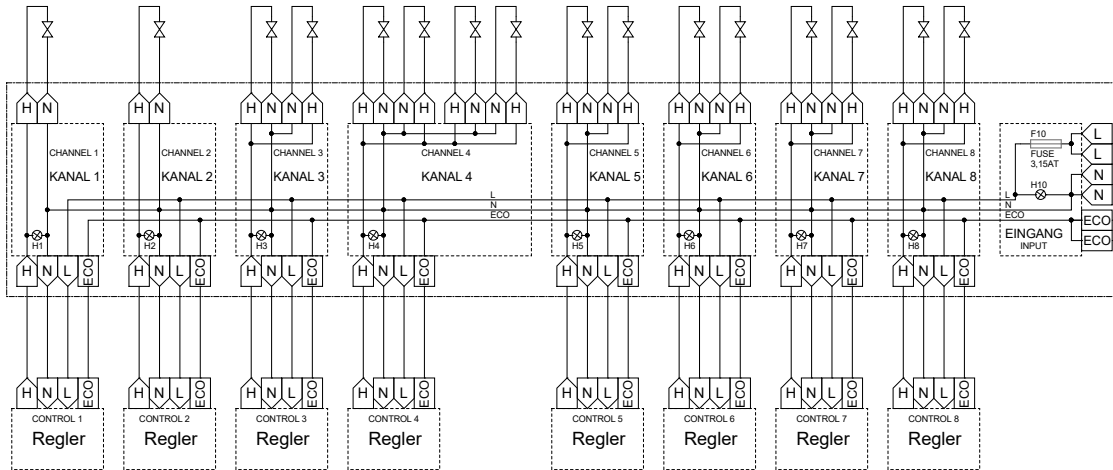

V00PL-216.176

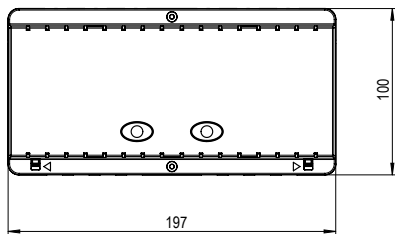
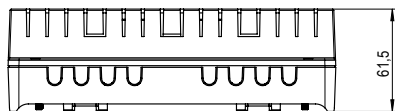

V00PL-318.178

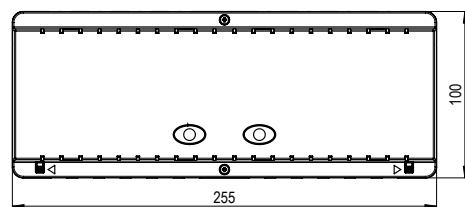
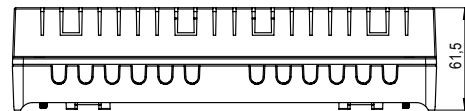



SAVE COSTS DURING HEATING
AND TIME DURING INSTALLATION.



EASY INSTALLATION – EXPLAINED IN 27s

NOW THE ELECTRICIAN CAN DO IT, TOO!





**alre –
simply
control.**

alre

ALRE-IT
REGELTECHNIK GMBH

Richard-Tauber-Damm 10
12277 Berlin, Germany

Phone: +49(0)30 399 84 0
Fax: +49(0)30 391 70 05
E-mail: mail@alre.de

www.alre.de